



<b>B</b>	Contest: <b>PROPOSED</b>	Category: <b>Intermediate</b>
	Date: <b>2010</b>	Program: <b>Known "A"</b>

wind direction

Pilot: \_\_\_\_\_

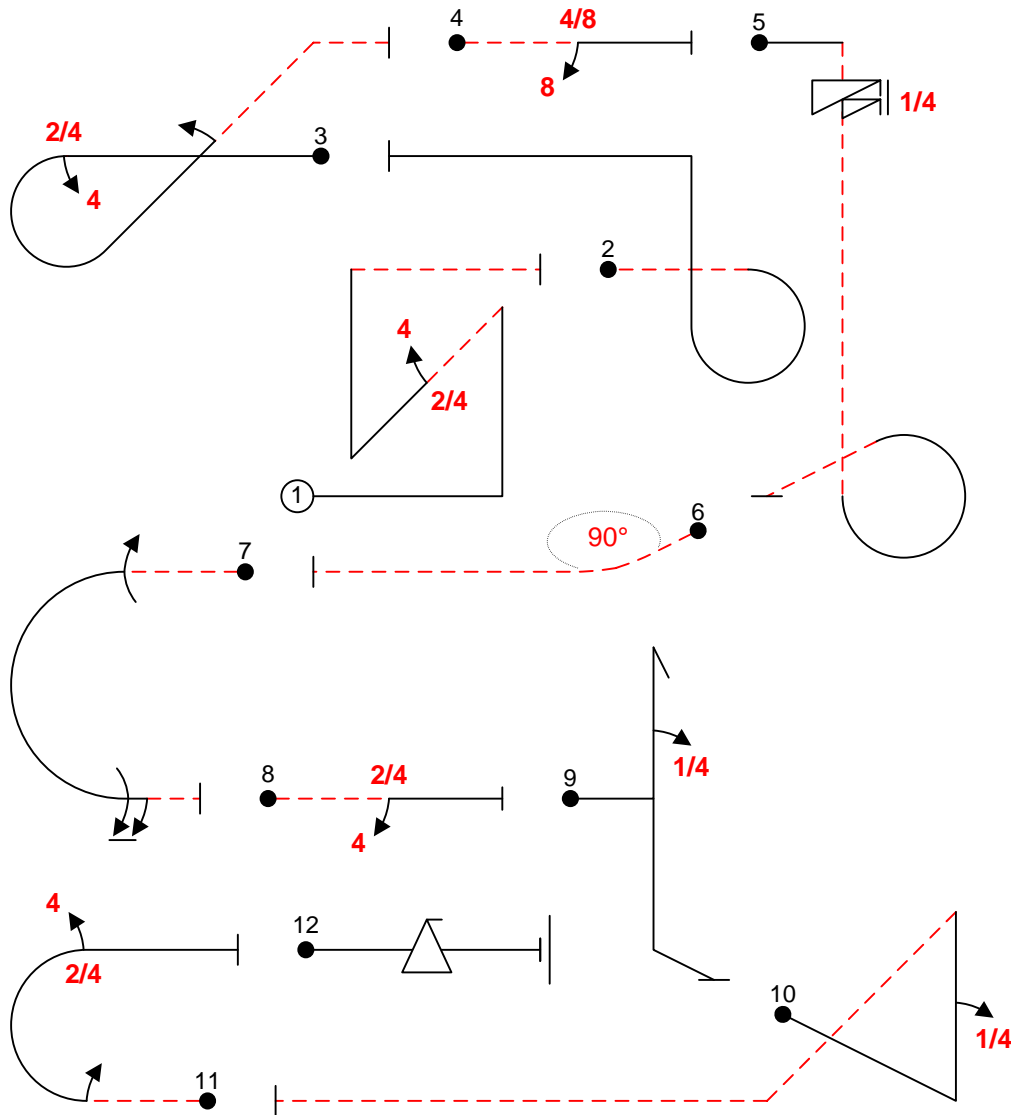

Fig 1	1.38.1 9.4.4.2	20 5	25
Fig 2	8.44.4	13	13
Fig 3	8.48.3 9.4.3.2 9.1.2.2	11 5 6	22
Fig 4	1.1.4 9.8.3.2	2 7	9
Fig 5	8.34.3 9.11.1.5	13 4	17
Fig 6	2.2.4	4	4
Fig 7	7.2.4 9.1.3.4 9.1.3.6	7 8 10	25
Fig 8	1.1.4 9.4.3.2	2 5	7
Fig 9	5.1.1 9.1.1.1	17 6	23
Fig 10	1.16.1 9.1.1.1	14 6	20
Fig 11	7.4.2 9.1.3.2 9.4.3.2	6 4 5	15
Fig 12	1.1.1 9.9.3.4	2 11	13
<b>Total K = 193</b>			

A/C: \_\_\_\_\_

(signature/date)

FREE PROGRAM CHECK BY: \_\_\_\_\_



<b>B</b>	Contest: <b>PROPOSED</b>	Category: <b>Intermediate</b>
	Date: <b>2010</b>	Program: <b>Known "B"</b>

wind direction

Pilot:

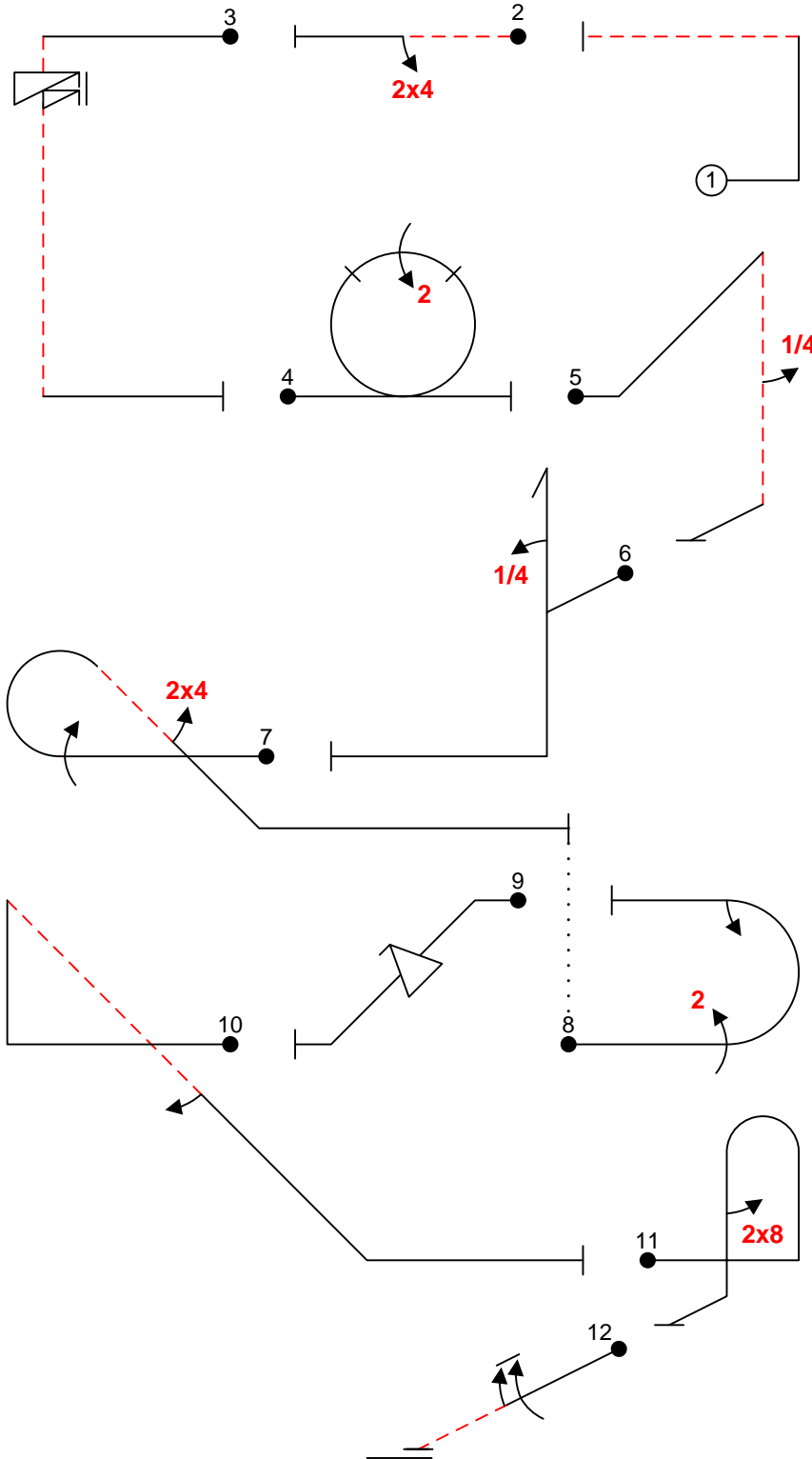

Fig 1	1.7.1	9	9
Fig 2	1.1.4 9.4.3.2	2 5	7
Fig 3	1.6.3 9.11.1.6	10 3	13
Fig 4	7.5.1 9.2.3.4 9.1.1.1	10 9 6	25
Fig 5	1.12.1 9.1.5.1	13 2	15
Fig 6	5.1.1	17	17
Fig 7	8.42.1 9.1.3.4 9.4.4.2	10 8 5	23
Fig 8	7.2.1 9.2.3.4 9.1.3.2	6 9 4	19
Fig 9	1.2.3 9.9.4.4	7 11	18
Fig 10	1.18.1 9.1.4.2	13 4	17
Fig 11	8.1.1 9.8.5.1	13 3	16
Fig 12	1.1.3 9.1.3.6	2 10	12

Total K = 191

A/C:

(signature/date)

FREE PROGRAM CHECK BY:



<b>B</b>	Contest: <b>PROPOSED</b>	Category: <b>Intermediate</b>
	Date: <b>2010</b>	Program: <b>Known "C"</b>

wind direction

Pilot:

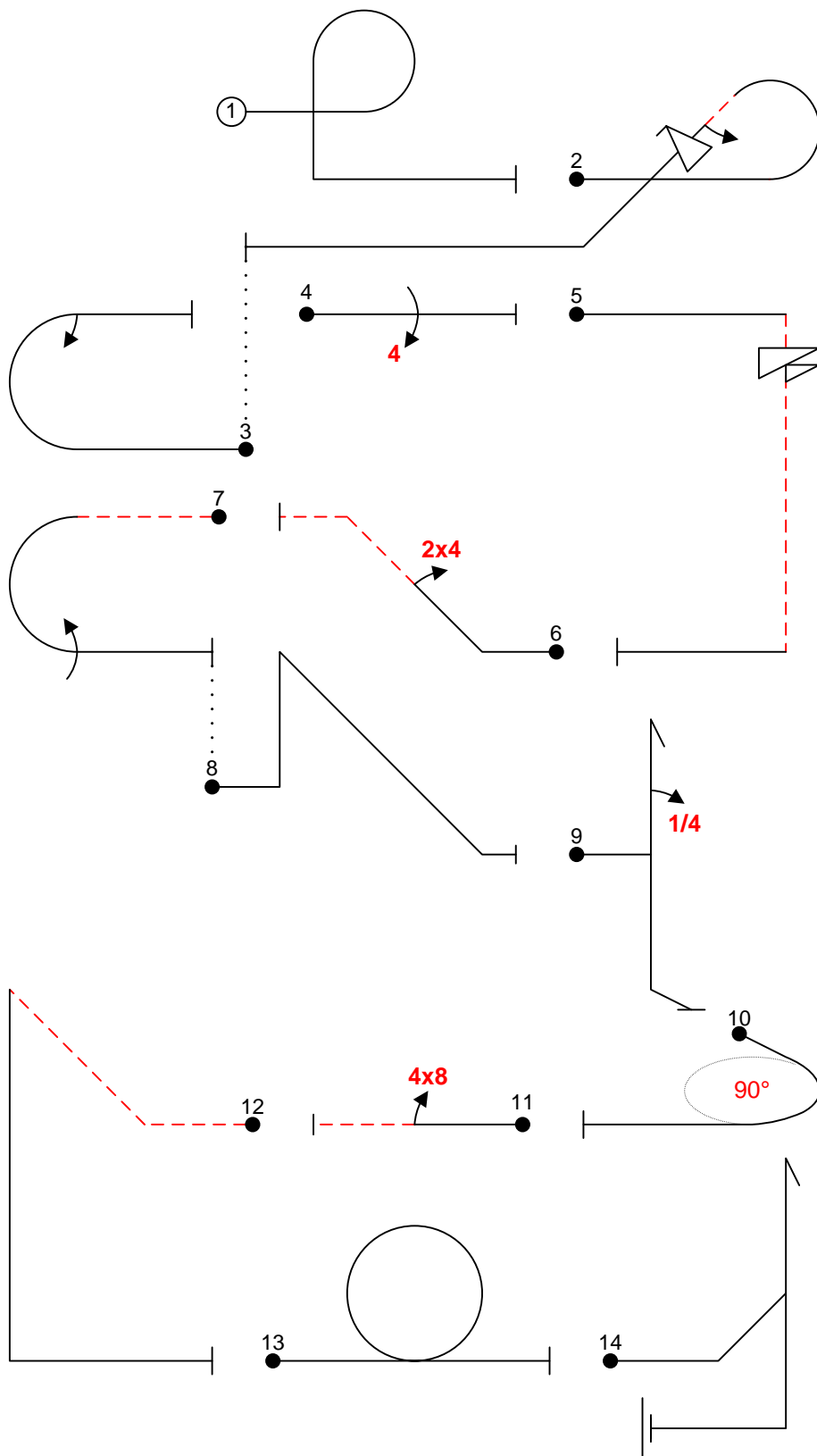

Fig 1	8.43.1	11	11
Fig 2	8.42.1	10	25
	9.1.4.2	4	
	9.9.4.4	11	
Fig 3	7.2.1	6	10
	9.1.3.2	4	
Fig 4	1.1.1	2	13
	9.4.3.4	11	
Fig 5	1.6.3	10	13
	9.11.1.6	3	
Fig 6	1.3.1	7	14
	9.4.2.2	7	
Fig 7	7.1.4	6	14
	9.1.3.4	8	
Fig 8	1.17.1	14	14
Fig 9	5.1.1	17	23
	9.1.1.1	6	
Fig 10	2.2.3	3	3
Fig 11	1.1.3	2	9
	9.8.3.2	7	
Fig 12	1.13.2	13	13
Fig 13	7.5.1	10	10
Fig 14	5.2.1	18	18

Total K = 190

A/C:

(signature/date)

FREE PROGRAM CHECK BY:



<b>B</b>	Contest: <b>PROPOSED</b>	Category: <b>Intermediate</b>
	Date: <b>2010</b>	Program: <b>Known "D"</b>

wind direction

Pilot:

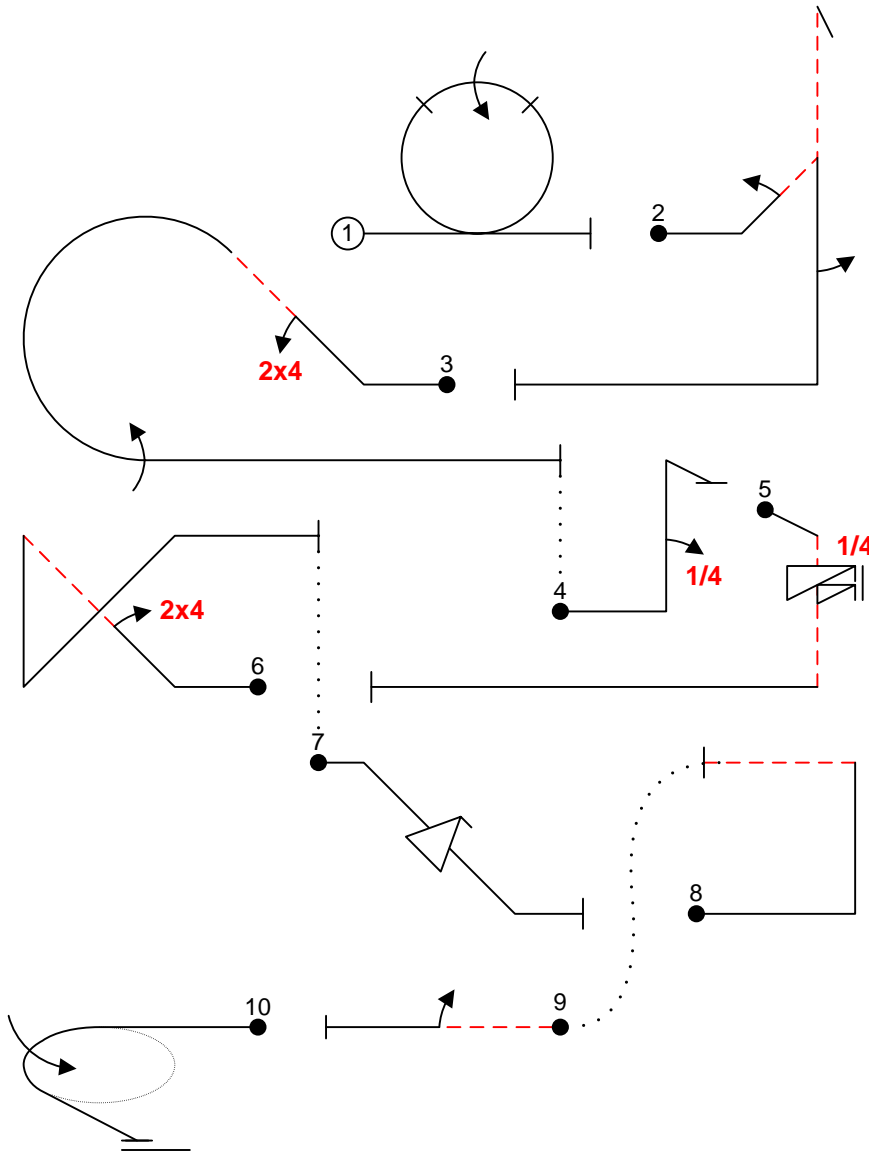

Fig 1	7.5.1 9.1.3.4	10 8	18
Fig 2	5.3.1 9.1.2.2 9.1.5.2	24 6 4	34
Fig 3	8.32.1 9.4.2.2 9.1.3.4	10 7 8	25
Fig 4	1.6.1 9.1.1.1	10 6	16
Fig 5	1.6.3 9.11.1.5	10 4	14
Fig 6	1.29.1 9.4.2.2	18 7	25
Fig 7	1.2.3 9.9.4.4	7 11	18
Fig 8	1.7.1	9	9
Fig 9	1.1.4 9.1.3.2	2 4	6
Fig 10	2.3.1	14	14

Total K = 179

A/C:

(signature/date)

FREE PROGRAM CHECK BY:



<b>B</b>	Contest: <b>PROPOSED</b>	Category: <b>Intermediate</b>
	Date: <b>2010</b>	Program: <b>Known "E"</b>

wind direction

Pilot:

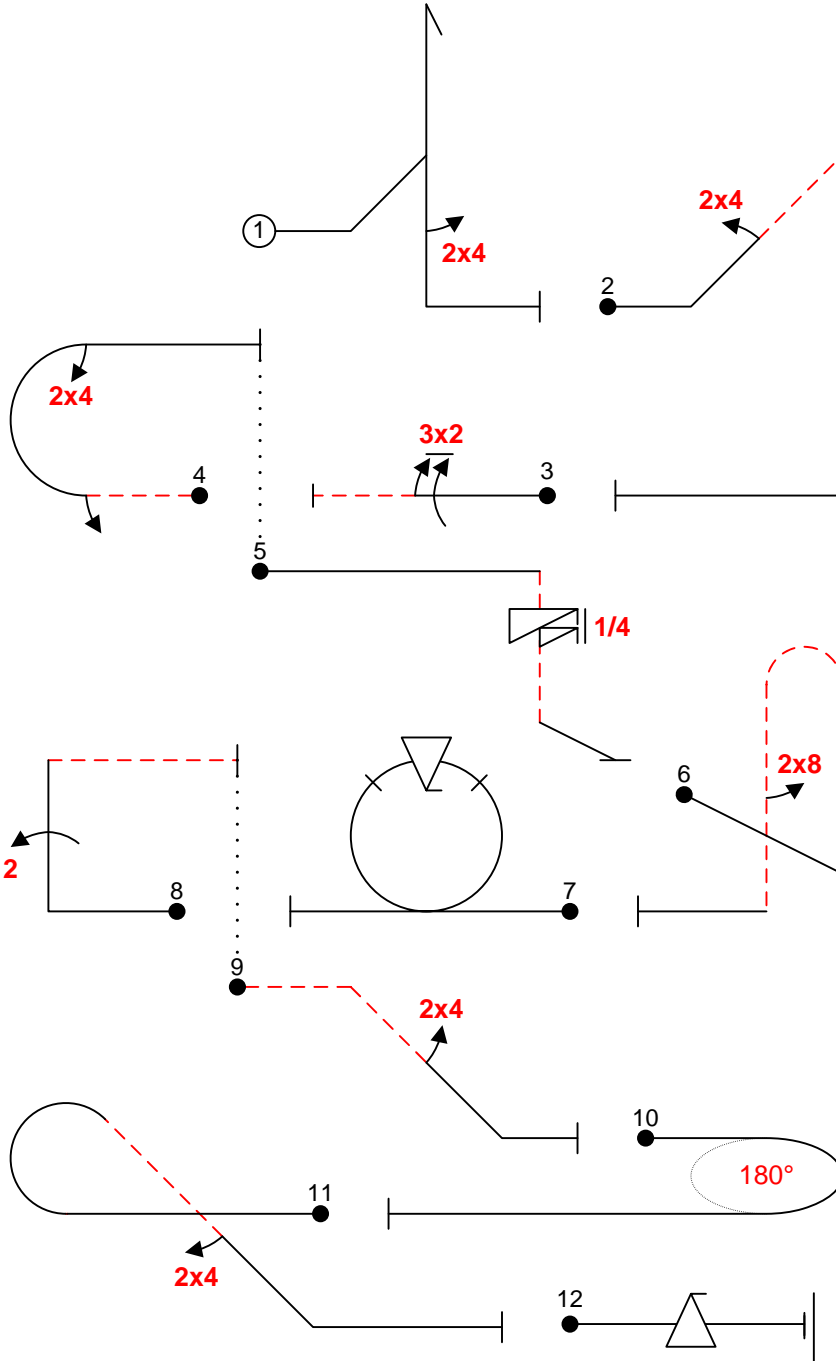

Fig 1	5.2.1 9.4.5.2	18 5	23
Fig 2	1.14.1 9.4.2.2	12 7	19
Fig 3	1.1.3 9.2.3.6	2 12	14
Fig 4	7.4.2 9.1.3.2 9.4.3.2	6 4 5	15
Fig 5	1.6.3 9.11.1.5	10 4	14
Fig 6	8.3.1 9.8.5.1	15 3	18
Fig 7	7.5.1 9.9.3.4	10 11	21
Fig 8	1.7.1 9.2.1.4	9 13	22
Fig 9	1.3.4 9.4.4.2	7 5	12
Fig 10	2.2.1	4	4
Fig 11	8.42.1 9.4.4.2	10 5	15
Fig 12	1.1.1 9.9.3.4	2 11	13

Total K = 190

A/C:

(signature/date)

FREE PROGRAM CHECK BY:



<b>B</b>	Contest: <b>PROPOSED</b>	Category: <b>Intermediate</b>
	Date: <b>2010</b>	Program: <b>Known "F"</b>

wind direction

Pilot: \_\_\_\_\_

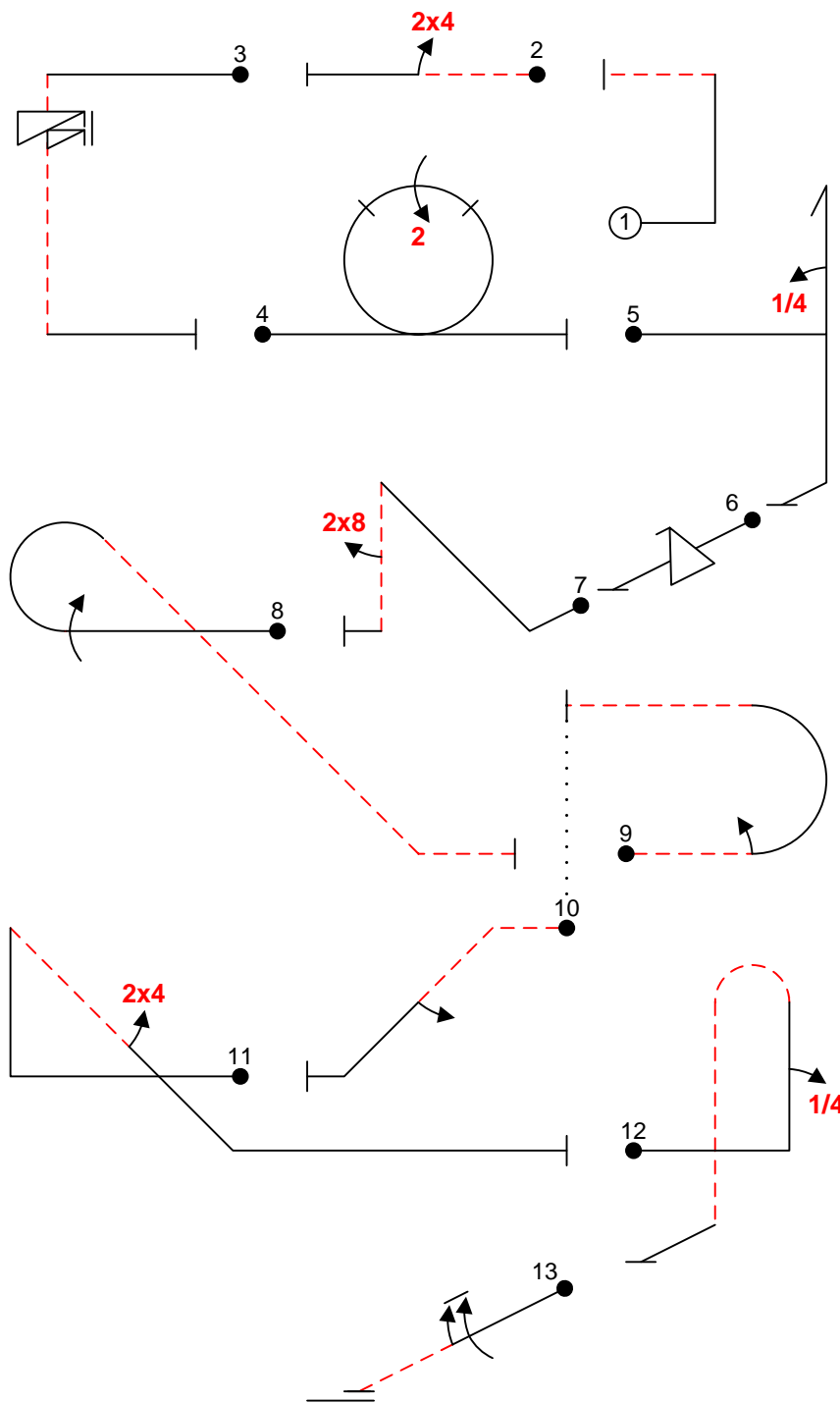

Fig 1	1.7.1 9.1.1.1	9 6	15
Fig 2	1.1.4 9.4.3.2 9.2.3.4	2 5 9	16
Fig 3	1.6.3 9.11.1.6	10 3	13
Fig 4	7.5.1	10	10
Fig 5	5.1.1	17	17
Fig 6	1.1.1 9.9.3.4	2 11	13
Fig 7	1.12.1 9.8.5.1	13 3	16
Fig 8	8.41.1 9.1.3.4	10 8	18
Fig 9	7.3.2 9.1.3.2	7 4	11
Fig 10	1.3.4 9.1.4.2	7 4	11
Fig 11	1.18.1 9.4.4.2	13 5	18
Fig 12	8.3.1 9.1.1.1	15 6	21
Fig 13	1.1.3 9.1.3.6	2 10	12

**Total K = 191**

A/C: \_\_\_\_\_

(signature/date)

FREE PROGRAM CHECK BY: \_\_\_\_\_



<b>B</b>	Contest: <b>PROPOSED</b>	Category: <b>Intermediate</b>
	Date: <b>2010</b>	Program: <b>Known "G"</b>

wind direction

Pilot:

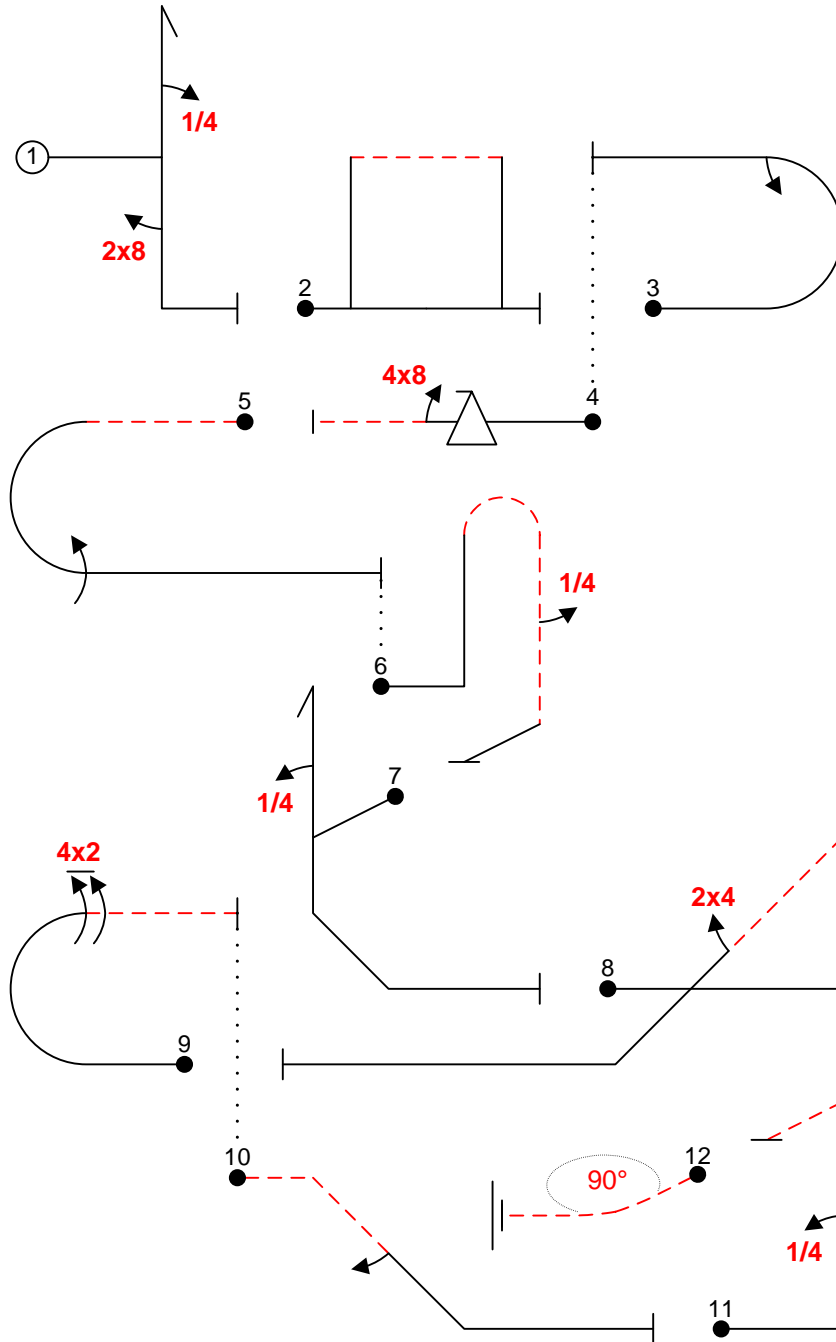

Fig 1	5.1.1 9.1.1.1 9.8.5.1	17 6 3	26
Fig 2	7.7.1	14	14
Fig 3	7.2.1 9.1.3.2	6 4	10
Fig 4	1.1.3 9.9.3.4 9.8.3.2	2 11 7	20
Fig 5	7.1.4 9.1.3.4	6 8	14
Fig 6	8.3.1 9.1.5.1 9.1.1.1	15 2 6	23
Fig 7	5.4.1	18	18
Fig 8	1.18.1 9.4.4.2	13 5	18
Fig 9	7.1.1 9.2.3.8	6 15	21
Fig 10	1.3.4 9.1.4.2	7 4	11
Fig 11	1.7.1 9.1.1.1	9 6	15
Fig 12	2.2.4	4	4
<b>Total K = 194</b>			

A/C:

(signature/date)

FREE PROGRAM CHECK BY:



<b>B</b>	Contest: <b>PROPOSED</b>	Category: <b>Intermediate</b>
	Date: <b>2010</b>	Program: <b>Known "H"</b>

wind direction

Pilot:

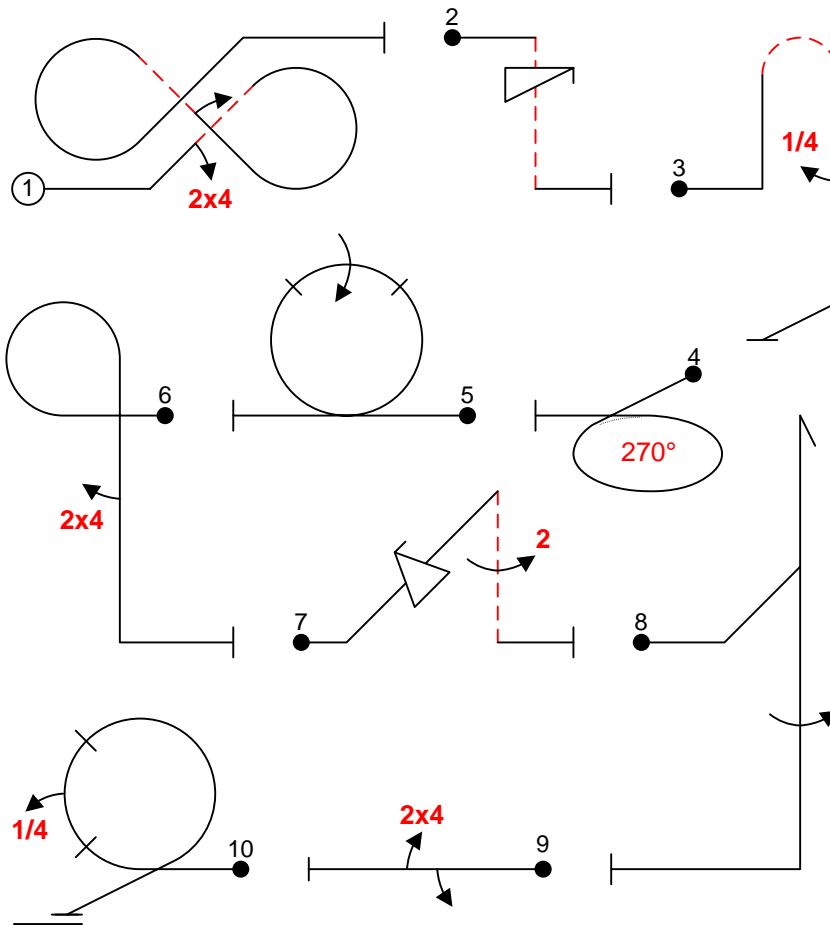

Fig 1	7.35.1 9.4.2.2 9.1.2.2	23 7 6	36
Fig 2	1.6.3 9.11.1.4	10 5	15
Fig 3	8.3.1 9.1.5.1	15 2	17
Fig 4	2.1.3	5	5
Fig 5	7.5.1 9.1.3.4	10 8	18
Fig 6	8.43.1 9.4.5.2	11 5	16
Fig 7	1.12.1 9.9.2.4 9.2.5.4	13 13 9	35
Fig 8	5.2.1 9.1.5.4	18 8	26
Fig 9	1.1.1 9.1.3.2 9.4.3.2	2 4 5	11
Fig 10	0.1	16	16
<b>Total K = 195</b>			

A/C:

(signature/date)

FREE PROGRAM CHECK BY:



<b>B</b>	Contest: <b>PROPOSED</b>	Category: <b>Intermediate</b>
	Date: <b>2010</b>	Program: <b>Known "I"</b>

wind direction

Pilot:

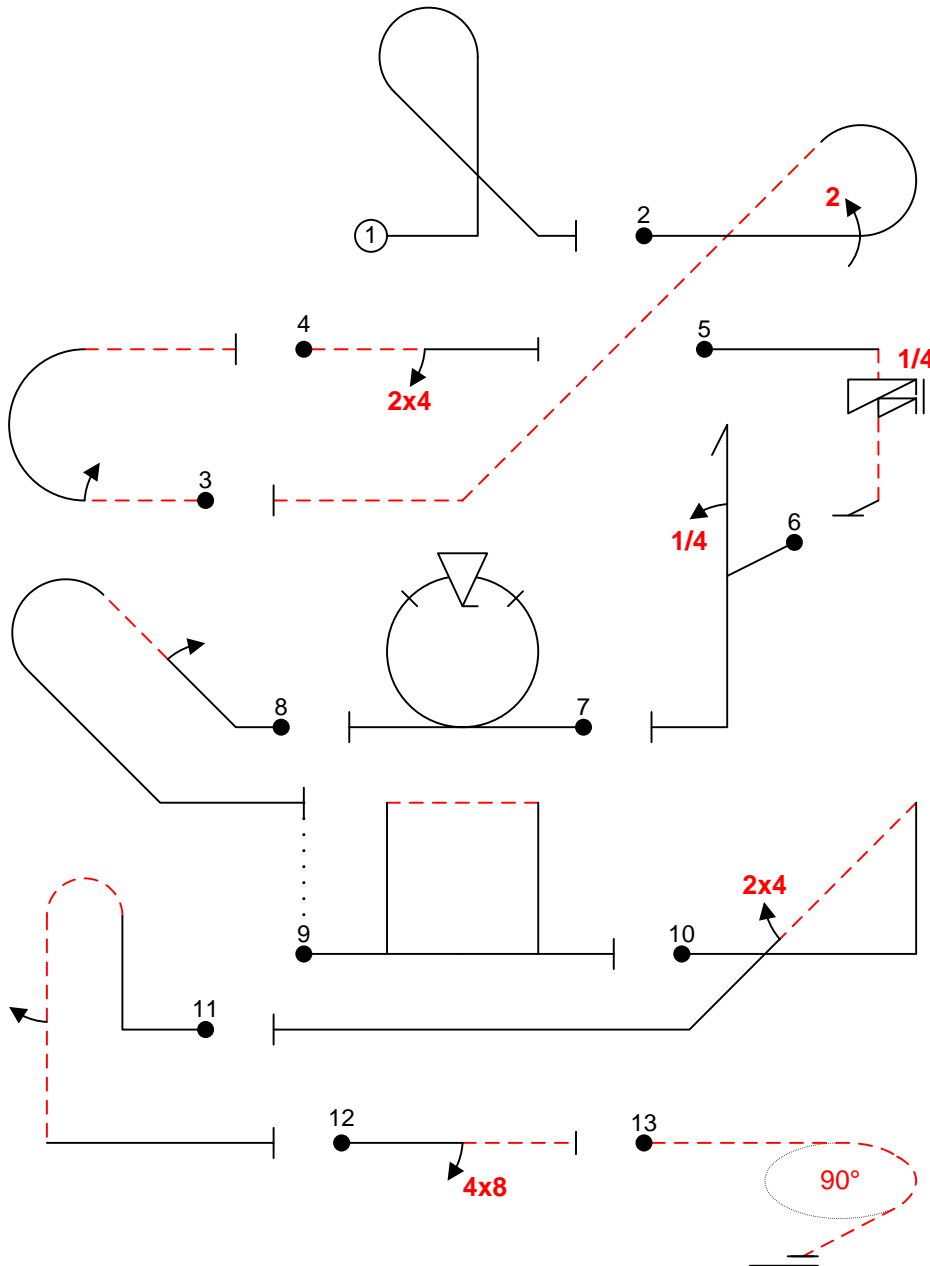

Fig 1	8.65.1	12	12
Fig 2	8.41.1 9.2.3.4	10 9	19
Fig 3	7.3.2 9.1.3.2	7 4	11
Fig 4	1.1.4 9.4.3.2	2 5	7
Fig 5	1.6.3 9.11.1.5	10 4	14
Fig 6	5.1.1 9.1.1.1	17 6	23
Fig 7	7.5.1 9.9.3.4	10 11	21
Fig 8	8.15.1 9.1.2.2	12 6	18
Fig 9	7.7.1	14	14
Fig 10	1.18.1 9.4.4.2	13 5	18
Fig 11	8.3.1 9.1.5.2	15 4	19
Fig 12	1.1.3 9.8.3.2	2 7	9
Fig 13	2.2.4	4	4
<b>Total K = 189</b>			

A/C:

(signature/date)

FREE PROGRAM CHECK BY:



<b>B</b>	Contest: <b>PROPOSED</b>	Category: <b>Intermediate</b>
	Date: <b>2010</b>	Program: <b>Known "J"</b>

wind direction

Pilot:

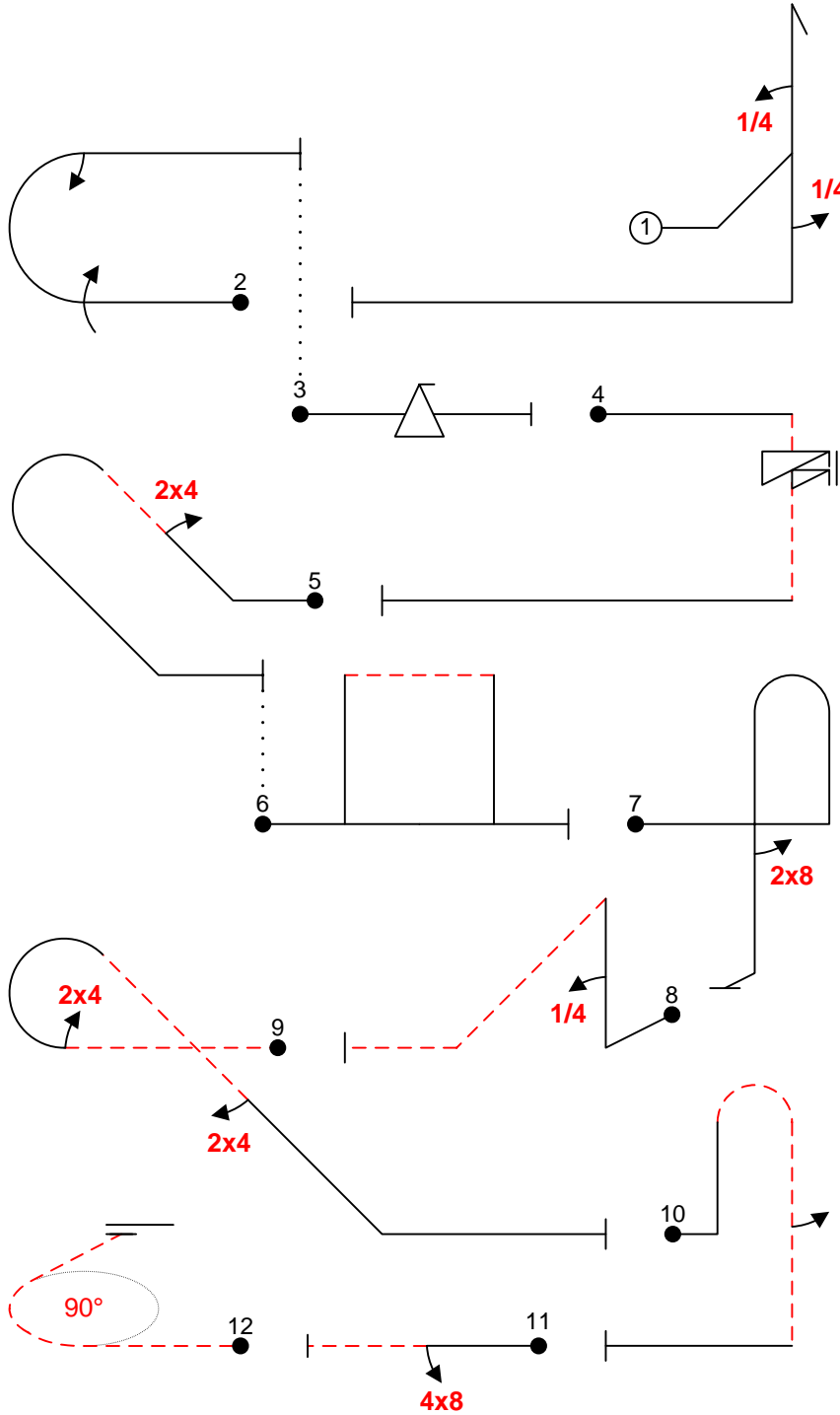

Fig 1	5.2.1 9.1.1.1 9.1.5.1	18 6 2	26
Fig 2	7.2.1 9.1.3.4 9.1.3.2	6 8 4	18
Fig 3	1.1.1 9.9.3.4	2 11	13
Fig 4	1.6.3 9.11.1.6	10 3	13
Fig 5	8.15.1 9.4.2.2	12 7	19
Fig 6	7.7.1	14	14
Fig 7	8.1.1 9.8.5.1	13 3	16
Fig 8	1.16.1 9.1.1.1	14 6	20
Fig 9	8.48.2 9.4.3.2 9.4.4.2	11 5 5	21
Fig 10	8.3.1 9.1.5.2	15 4	19
Fig 11	1.1.3 9.8.3.2	2 7	9
Fig 12	2.2.4	4	4
<b>Total K = 192</b>			

A/C:

(signature/date)

FREE PROGRAM CHECK BY:



<b>B</b>	Contest: <b>PROPOSED</b>	Category: <b>Intermediate</b>
	Date: <b>2010</b>	Program: <b>Known "K"</b>

wind direction

Pilot:

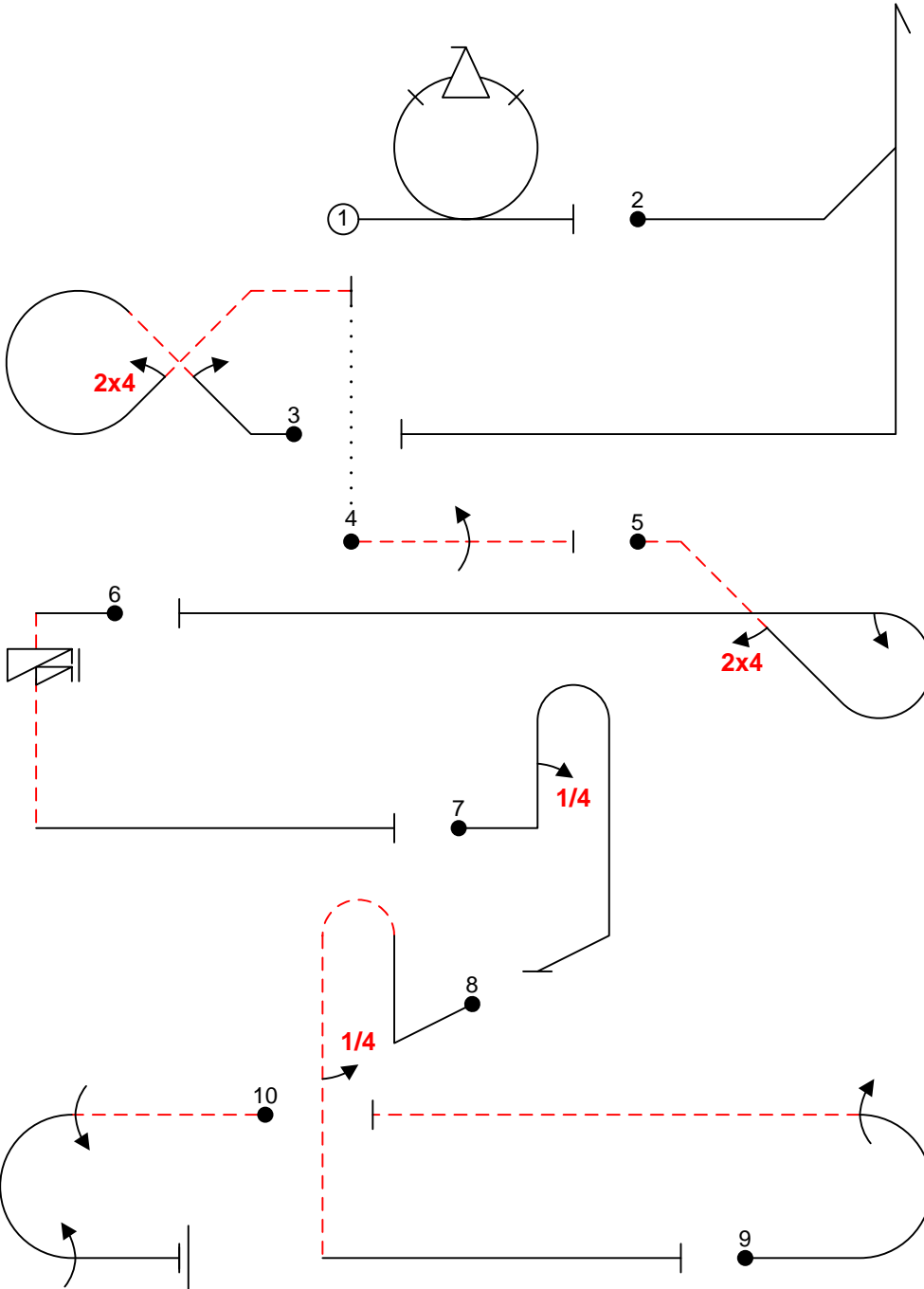

Fig 1	7.5.1 9.9.3.4	10 11	21
Fig 2	5.2.1	18	18
Fig 3	7.22.1 9.1.2.2 9.4.2.2	16 6 7	29
Fig 4	1.1.2 9.1.3.4	3 8	11
Fig 5	8.38.4 9.4.4.2 9.1.3.2	11 5 4	20
Fig 6	1.6.3 9.11.1.6	10 3	13
Fig 7	8.1.1 9.1.1.1	13 6	19
Fig 8	8.3.1 9.1.5.1	15 2	17
Fig 9	7.1.1 9.1.3.4	6 8	14
Fig 10	7.1.4 9.1.3.4 9.1.3.4	6 8 8	22

Total K = 184

A/C:

(signature/date)

FREE PROGRAM CHECK BY:



<b>B</b>	Contest: <b>PROPOSED</b>	Category: <b>Intermediate</b>
	Date: <b>2010</b>	Program: <b>Known "L"</b>

wind direction

Pilot:

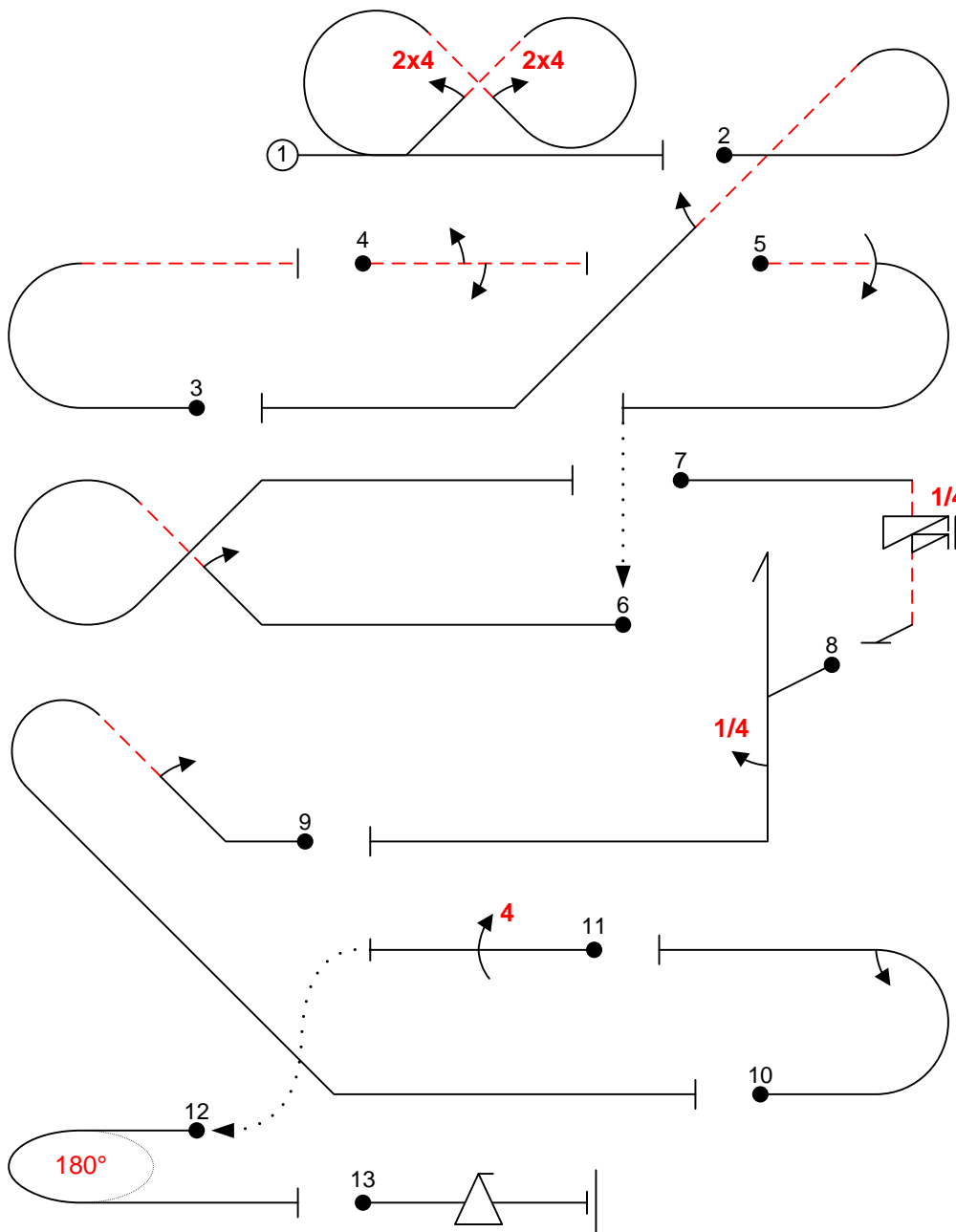

Fig 1	7.30.1 9.4.2.2 9.4.2.2	19 7 7	33
Fig 2	8.42.1 9.1.4.2	10 4	14
Fig 3	7.1.1	6	6
Fig 4	1.1.2 9.1.3.2 9.1.3.2	3 4 4	11
Fig 5	7.1.4 9.1.3.4	6 8	14
Fig 6	7.20.1 9.1.2.2	14 6	20
Fig 7	1.6.3 9.11.1.5	10 4	14
Fig 8	5.1.1 9.1.5.1	17 2	19
Fig 9	8.15.1 9.1.2.2	12 6	18
Fig 10	7.2.1 9.1.3.2	6 4	10
Fig 11	1.1.1 9.4.3.4	2 11	13
Fig 12	2.2.1	4	4
Fig 13	1.1.1 9.9.3.4	2 11	13

Total K = 189

A/C:

(signature/date)

FREE PROGRAM CHECK BY: